

Steel Tubes

Heavy-weight Suitable for Screwing

DIN

2441

Stahlrohre; Schwere Gewinderohre

In the nominal widths and tube dimensions quoted, this Standard corresponds to ISO 65 – 1973 issued by the International Organization for Standardization (ISO), see Explanations.

1 Scope

Dimensions in mm

This Standard applies to heavy-weight tubes suitable for screwing. They are suitable for nominal pressure 25 for liquids and nominal pressure 10 for air and non-hazardous gases.

2 Other relevant Standards

- DIN 2444 Zinc coatings on steel tubes; quality standard for the hot galvanizing of steel tubes for installation purposes
- DIN 2999 Part 1 Whitworth pipe threads for tubes and fittings; cylindrical internal thread and conical external thread; thread dimensions
- DIN 17 100 Steels for general structural purposes; quality specifications
- DIN 50 136 Testing of metallic materials; flattening test on tubes

3 Dimensions, designation

Regular type

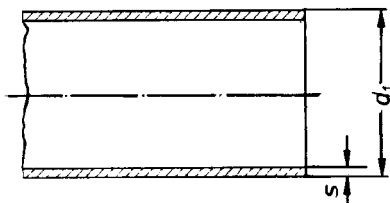

Conical screw thread (when ordered with screw thread)

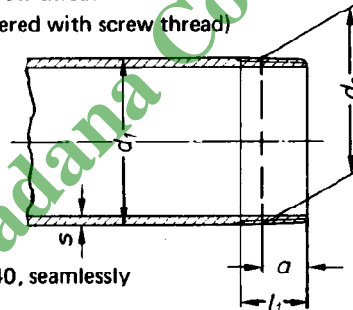

Designation of a heavy-weight tube suitable for screwing, nominal width 40, seamlessly galvanized (B) in manufacturing lengths:

Table 1. Threaded tube DIN 2441 – DN 40 – seamless B

Nom- inal width DN	Connect- ing nominal width of the fittings according to DIN 2950 and DIN 2980	Whit- worth pipe threads according to DIN 2999 Part 1	Tube				Screw thread				Corresponding socket according to DIN 2986		
			Out- side diam- eter d_1	Wall thick- ness s	Weight of plain- end tube kg/m	Weight of socketed tube ¹⁾ kg/m	Theo- retical screw thread diam- eter d_2	Threads per 25,4 mm	Usable screw thread length l_1 min. at a max.	Distance of screw thread diam- eter d_2 from tube end		Outside diam- eter	Length
									a max.	a min.	min.	min.	
6	1/8	R 1/8	10,2	2,65	0,493	0,496	9,728	28	7,4	4,9	3,1	14	17
8	1/4	R 1/4	13,5	2,9	0,769	0,773	13,157	19	11,0	7,3	4,7	18,5	25
10	3/8	R 3/8	17,2	2,9	1,02	1,03	16,662	19	11,4	7,7	5,1	21,3	26
15	1/2	R 1/2	21,3	3,25	1,45	1,46	20,955	14	15,0	10,0	6,4	26,4	34
20	3/4	R 3/4	26,9	3,25	1,90	1,91	26,441	14	16,3	11,3	7,7	31,8	36
25	1	R 1	33,7	4,05	2,97	2,99	33,249	11	19,1	12,7	8,1	39,5	43
32	1 1/4	R 1 1/4	42,4	4,05	3,84	3,87	41,910	11	21,4	15,0	10,4	48,3	48
40	1 1/2	R 1 1/2	48,3	4,05	4,43	4,47	47,803	11	21,4	15,0	10,4	54,5	48
50	2	R 2	60,3	4,5	6,17	6,24	59,614	11	25,7	18,2	13,6	66,3	56
65	2 1/2	R 2 1/2	76,1	4,5	7,90	8,02	75,184	11	30,2	21,0	14,0	82	65
80	3	R 3	88,9	4,85	10,1	10,3	87,884	11	33,3	24,1	17,1	95	71
100	4	R 4	114,3	5,4	14,4	14,7	113,030	11	39,3	28,9	21,9	122	83
125	5	R 5	139,7	5,4	17,8	18,3	138,430	11	43,6	32,1	25,1	147	92
150	6	R 6	165,1	5,4	21,2	21,8	163,830	11	43,6	32,1	25,1	174	92

¹⁾ Referred to an average length of 6 m

A decision with regard to the method of designation for fittings will be taken at the time when the currently existing ISO Recommendation is converted to ISO Standards, due consideration being given to international practice regarding the designation of tubes suitable for screwing.

Continued on pages 2 and 3
Explanations on page 4

4 Screw thread

Whitworth pipe threads according to DIN 2999 Part 1, taper 1 : 16

5 Material

St 33-2 according to DIN 17 100, material number 1.0035

In general, suitability for fusion welding according to this Standard exists.

Neither the crystalline condition nor any variation in hardness occurring over the circumference and brought about by the manufacturing process may impair the proper threading of the tubes.

6 Execution

Seamless or welded

7 Mode of delivery

In manufacturing lengths without screw thread and without socket. If another mode of delivery is required, the designation shall be augmented as follows:

For supply with conical screw thread at both ends: with screw thread

For supply with conical screw thread at both ends and one socket screwed on: with socket

Example for the tube with conical screw thread at both ends mentioned in the example of designation:

Threaded tube DIN 2441 – DN 40 – seamless B with screw thread

8 Surface treatment

According to the order, the tubes are supplied in the following types:

Table 2.

Surface	Symbol
black	T
black, suitable for galvanizing according to Section 10.3	A
galvanized according to DIN 2444	B
non-metallic protective coating ²⁾ outside	C
inside	D
2) According to agreement	

The types of surface treatment can also be combined.

For example:

Non-metallic protective coating
outside on galvanized tube BC

If nothing is stated, the tubes will be supplied "black".

9 Marking

Welded tubes suitable for screwing in nominal widths 10 to 150 are to be marked continuously at approximately 1 m intervals with the manufacturer's sign in a durable and readily recognizable manner.

Seamless tubes suitable for screwing are to be marked on one end of the tube with the manufacturer's sign in a durable and readily recognizable manner.

10 Technical conditions of delivery

10.1 Screw threads

The screw threads must correspond to DIN 2999 Part 1. The screw thread diameter d_2 is measured at distance a from the tube end over the crests of the screw threads. The last threads at the extremity may be incomplete.

10.2 Surface

The tubes must have a smooth outside and inside surface consistent with the kind of manufacture. Slivers, scabs, foliations and the like must be removed. This however must not cause the wall thickness to go below the permissible deviation.

10.2.1 In the case of welded tubes, the weld must show full penetration and be devoid of any major non-metallic inclusions and other defects. On the inside there must be no evidence of droplets of weld metal having penetrated. The height of the welding fin on the inside shall not exceed 60 % of the nominal wall thickness.

The external welding fin (upset bead) shall in all cases be removed from tubes electrically welded with pressure.

10.3 Suitability for galvanizing

(Symbol for ordering purposes "A")

Over and above the requirements to be met by the surface condition according to Section 10.2, the projection of the inner welding fin shall not exceed $0.3 \text{ mm} + 0.05 \cdot s$ in the case of welded tubes which are suitable for galvanizing according to DIN 2444.

The welding fin must not be fissured.

10.4 Lengths

The tubes are normally supplied in manufacturing lengths.

10.4.1 The usual manufacturing lengths for welded tubes are:

$$6 \text{ m} \begin{matrix} + \\ - \end{matrix} \begin{matrix} 100 \\ 50 \end{matrix} \text{ mm}$$

According to occurrence, up to 6 % of the quantity delivered will be supplied in lengths between 5 m and 5.95 m, separately bundled.

10.4.2 The usual manufacturing lengths for seamless tubes are:

$$6 \text{ m} \pm 1 \text{ m}$$

According to occurrence, up to 10 % of the quantity delivered will be supplied in lengths of more than 4 m to below 5 m or of more than 7 m to below 8 m, separately bundled in each case.

10.4.3 Supply of the tubes in other types of length is to be agreed separately, e.g. exact lengths.

The measurement to be specified when ordering will be complied with to within a deviation of $\begin{matrix} + \\ 0 \end{matrix} 15 \text{ mm}$.

Detail of order: Exact length m

Example:

Tube suitable for screwing DIN 2441 – DN 40 – seamless B with screw thread, exact length 7 m

10.5 Permissible dimensional deviations

Table 3.

Nominal width DN	d_1	d_1
	max.	min.
6	10,6	9,8
8	14,0	13,2
10	17,5	16,7
15	21,8	21,0
20	27,3	26,5
25	34,2	33,3
32	42,9	42,0
40	48,8	47,9
50	60,8	59,7
65	76,6	75,3
80	89,5	88,0
100	115,0	113,1
125	140,8	138,5
150	166,5	163,9

Wall thickness

– 12.5% (– 15% at individual points not longer than 2 X the outside diameter, provided that this reduction is effective only on the outer surface).

The upper limit is fixed by the permissible weight deviation.

10.6 Weight deviation

Compared with the weights specified in the table on page 1 deviations according to the following table are permissible.

Table 4.

for a single tube	for a consignment of not less than 10 t
± 10 %	± 7.5 %

10.7 Straightness

The tubes must appear straight to the eye.

10.8 Cold bending capability

Tubes suitable for screwing according to this Standard without surface treatment must be capable of being bent cold by means of a suitable commercial bending tool to a radius of 3 X tube outside diameter up to and including DN 25, and to a radius of 3.5 X tube outside diameter in the case of tubes up to nominal width 50 (see Section 11.4).

11 Testing

11.1 Material

The mechanical properties of the material are covered by the data in DIN 17 100.

No acceptance by an expert takes place, nor is a works certificate based on material tests being issued.

11.2 Leak testing

All tubes are to be tested in the manufacturer's works for absence of leaks. If this test is effected by internal hydraulic pressure, the test pressure used shall be 50 bar. Instead of the internal hydraulic pressure test, the manufacturer may also perform another test, e.g. an eddy current test³⁾ verified as ensuring equivalent quality.

If so specified in the order, the manufacturer issues a statement of compliance with the order in respect of the test performed for leak tightness.

The test for absence of leaks applies only to the unmachined tube and not to the joint.

Tubes which fail the leak testing are to be eliminated.

11.3 Annular flattening test

As a technological test on tubes welded with pressure, the annular flattening test according to DIN 50 136 shall be performed on random samples for quality control of the welding. In the annular flattening test the specimens or tube ends are to be compressed until the distance between the two pressure platens reaches 2/3 of the original outside diameter of the tube without causing the weld to open. The weld shall lie alternately in the vertical plane (12 o'clock position) and in the horizontal plane (3 o'clock position).

11.4 Bending test

On tubes up to and including DN 50 the bending test shall be carried out on random samples as a technological test for verifying the cold bending capability.

In the bending test a suitable commercial type bending tool is used to bend the tube at a radius of 3.0 or 3.5 X tube outside diameter to make a 90° bend. This shall not cause any cracking.

In the case of welded tubes the weld shall not exhibit any incipient cracking. The weld shall lie alternately in the vertical plane (12 o'clock position) and in the horizontal plane (3 o'clock position).

12 Complaints

External and internal defects other than those stated in the Standard may only be objected to if they impair the proper processing and/or utilization of the tubes in an appropriate manner.

The customer must give the supplier an opportunity of satisfying himself that the complaint is justified, and when possible shall do this by submitting the material objected to as well as specimens of the material as supplied.

³⁾ According to Stahl-Eisen-Prüfblatt (Steel-Iron Data Sheet) 1925 obtainable from Verlag Stahl-Eisen, Postfach 8229, 4000 Düsseldorf 1

Explanations

The revision of the Standards dealing with tubes suitable for screwing, the dimension provisions of which are fully in agreement with the International Standard ISO 65 – 1973, had become necessary because recent findings had revealed more far-reaching quality requirements to be indispensable.

Corrosion damage on welded tubes suitable for screwing has shown that for galvanized tubes reduction of the internal welding fin must take place if the requirements stipulated in Section 10.3 have not been observed.

The tube may be ordered at option with or without screw thread and with or without socket. This takes account of the usual practical applications in which the tubes are mostly cut to shorter lengths and a taper screw thread to DIN 2999 Part 1 is then cut on each end of these lengths.

Newly included is the subdivision of the ordering symbols for black tubes into:

black	—
black, suitable for galvanizing	A

The marking of welded tubes with the manufacturer's sign has been extended to cover the range DN 10 to 150. Seamless tubes suitable for screwing are to be marked durably with the manufacturer's sign on one end of the tube.

Finally, in order to ensure proper workability of the tubes, random sample checking of the welded tubes by means of the annular flattening test and of seamless and welded tubes up to DN 50 by means of the bending test has been included.

Kowsar San'at Espadana Co.