



**American Water Works
Association**

The Authoritative Resource on Safe Water®

AWWA C200-05
(Revision of ANSI/AWWA C200-97)

AWWA Standard

Steel Water Pipe—6 In. (150 mm) and Larger



Kowsar San'at Espadana Co.

Effective date: March 1, 2007.

First edition approved by AWWA Board of Directors June 26, 1975.

This edition approved June 12, 2005.

6666 West Quincy Avenue
Denver, CO 80235-3098
T 800.926.7337
www.awwa.org

Advocacy
Communications
Conferences
Education and Training
► **Science and Technology**
Sections

AWWA Standard

This document is an American Water Works Association (AWWA) standard. It is not a specification. AWWA standards describe minimum requirements and do not contain all of the engineering and administrative information normally contained in specifications. The AWWA standards usually contain options that must be evaluated by the user of the standard. Until each optional feature is specified by the user, the product or service is not fully defined. AWWA publication of a standard does not constitute endorsement of any product or product type, nor does AWWA test, certify, or approve any product. The use of AWWA standards is entirely voluntary. AWWA standards are intended to represent a consensus of the water supply industry that the product described will provide satisfactory service. When AWWA revises or withdraws this standard, an official notice of action will be placed on the first page of the classified advertising section of *Journal AWWA*. The action becomes effective on the first day of the month following the month of *Journal AWWA* publication of the official notice.

Kowsar San'at Espadana Co.

Science and Technology

AWWA unites the entire water community by developing and distributing authoritative scientific and technological knowledge. Through its members, AWWA develops industry standards for products and processes that advance public health and safety. AWWA also provides quality improvement programs for water and wastewater utilities.

All rights reserved. No part of this publication may be reproduced or transmitted in any form or by any means, electronic or mechanical, including photocopy, recording, or any information or retrieval system, except in the form of brief excerpts or quotations for review purposes, without the written permission of the publisher.

Copyright © 2007 by American Water Works Association
Printed in USA

Committee Personnel

The Steel Water Pipe-Manufacturer's Technical Advisory Committee (SWPMTAC) Task Group on updating AWWA C200 had the following personnel at the time:

Dennis Dechant, *Chair*
Henry H. Bardakjian, *Vice-Chair*

H.H. Bardakjian, Ameron Concrete & Steel Pipe, Rancho Cucamonga, Calif. (AWWA)
R.J. Card, Victaulic Depend-o-Lok Inc., Atlanta, Ga. (AWWA)
B.D. Keil, Continental Pipe Manufacturing Company, Pleasant Grove, Utah (SPFA)
M. Mintz, M-Square Associates Inc., Elmont, N.Y. (AWWA)
R.S. Panter, Georgia Tubular Products, Cartersville, Ga. (AWWA)
G.F. Ruchti, American SpiralWeld Pipe Company, Punta Gorda, Fla. (AWWA)
R.N. Satyarathi, Baker Coupling Company Inc., Los Angeles, Calif. (AWWA)
B. Terrell, RTLK Piping Products Inc., Kosse, Texas (AWWA)
M. Topps, Glynwed Pipe Systems, Hixson, Tenn. (AWWA)
B.F. Vanderploeg, Northwest Pipe Company, Portland, Ore. (AWWA)
D.R. Wagner, Consultant, St. Louis, Mo. (AWWA)
N. Williams, National Welding Corporation, Midvale, Utah (AWWA)

The AWWA Standards Committee on Steel Pipe, which reviewed and approved this standard, had the following personnel at the time of approval:

John H. Bambei Jr., *Chair*
George J. Tupac, *Vice-Chair*
Dennis Dechant, *Secretary*

General Interest Members

W.R. Brunzell, Brunzell Associates Ltd., Skokie, Ill. (AWWA)
R.L. Coffey, Kirkham Michael Consulting Engineers, Omaha, Neb. (AWWA)
H.E. Dunham, Montgomery Watson Harza, Bellevue, Wash. (AWWA)
K.G. Ferguson,* Montgomery Watson Harza, Las Vegas, Nev. (AWWA)
S.N. Foellmi, Black & Veatch Corporation, Irvine, Calif. (AWWA)

* Alternate

J.W. Green, Alvord Burdick & Howson, Lisle, Ill.	(AWWA)
K.D. Henrichsen, HDR Engineering Inc., Denver, Colo.	(AWWA)
M.B. Horsley,* Black & Veatch Corporation, Overland Park, Kan.	(AWWA)
J.K. Jeyapalan, Pipeline Consultant, New Milford, Conn.	(AWWA)
R. Ortega, Lockwood Andrews & Newman, Houston, Texas	(AWWA)
A.E. Romer, Boyle Engineering Corporation, Newport Beach, Calif.	(AWWA)
H.R. Stoner, Consultant, North Plainfield, N.J.	(AWWA)
C.C. Sundberg, CH2M Hill Inc., Bellevue, Wash.	(AWWA)
G.J. Tupac, G.J. Tupac & Associates Inc., Pittsburgh, Pa.	(AWWA)
J.S. Wailes,† Standards Engineer Liaison, AWWA, Denver, Colo.	(AWWA)
W.R. Whidden, Post Buckley Schuh & Jernigan, Orlando, Fla.	(AWWA)
M.C. Young,† Bucher Willis & Ratliff Corporation, Kansas City, Mo.	(AWWA)

Producer Members

H.H. Bardakjian, Ameron International, Rancho Cucamonga, Calif.	(AWWA)
R.J. Card, Victaulic Depend-o-Lok Inc., Atlanta, Ga.	(AWWA)
R.R. Carpenter, American Cast Iron Pipe Company, Birmingham, Ala.	(MSS)
D. Dechant, Northwest Pipe Company, Denver, Colo.	(AWWA)
B.D. Keil, Continental Pipe Manufacturing Company, Pleasant Grove, Utah	(SPFA)
J.L. Luka,* American Spiral Weld Pipe Company, Columbia, S.C.	(AWWA)
B. Vanderploeg,* Northwest Pipe Company, Portland, Ore.	(AWWA)
J.A. Wise, Canus International Sales Inc., Maple Ridge, B.C.	(AWWA)

User Members

G.A. Andersen, New York City Department of Environmental Protection, Little Neck, N.Y.	(AWWA)
J.H. Bambei Jr., Denver Water Department, Denver, Colo.	(AWWA)
D.W. Coppes, Massachusetts Water Resources Authority, Southborough, Mass.	(NEWWA)

* Alternate

† Liaison, nonvoting

R.V. Frisz, US Bureau of Reclamation, Denver, Colo.	(BUREC)
T.R. Jervis, Greater Vancouver Regional District, Burnaby, B.C.	(AWWA)
T.J. Jordan, Metropolitan Water District of Southern California, La Verne, Calif.	(AWWA)
T.A. Larson, Tacoma Public Utilities, Tacoma, Wash.	(AWWA)
G.P. Stine, San Diego County Water Authority, San Diego, Calif.	(AWWA)
M. Taghavi, Los Angeles Dept. of Water & Power, Los Angeles, Calif.	(AWWA)
J.V. Young, City of Richmond, Richmond, B.C.	(AWWA)

Kowsar San'at Espadana Co.

This page intentionally blank.

Kowsar San'at Espadana Co.

Contents

All AWWA standards follow the general format indicated subsequently. Some variations from this format may be found in a particular standard.

SEC.	PAGE	SEC.	PAGE
Foreword			
I	Introduction.....ix	4.8	Selection of Materials..... 11
I.A	Background.....ix	4.9	General Requirements for Fabrication of Pipe 11
I.B	History.....ix	4.10	Fabrication of Pipe 11
I.C	Acceptance x	4.11	Requirements for Welding Operations 12
II	Special Issues.....xi	4.12	Permissible Variations in Weights and Dimensions 17
II.A	Advisory Information on Product Applicationxi	4.13	Preparation of Ends 18
III	Use of This Standardxiii	4.14	Special Ends..... 22
III.A	Purchaser Options and Alternatives ..xiii	4.15	Specials and Fittings 22
III.B	Modification to Standard..... xiv	4.16	Fabrication of Specials 23
IV	Major Revisions xv	5	Verification
V	Comments xv	5.1	Inspection 23
Standard			
1	General	5.2	Test Procedures..... 24
1.1	Scope 1	5.3	Calibration of Equipment..... 26
1.2	Purpose 1	6	Delivery
1.3	Application 1	6.1	Marking..... 26
2	References..... 2	6.2	Handling and Loading..... 27
3	Definitions 4	6.3	Affidavit of Compliance..... 27
4	Requirements	Figures	
4.1	Permeation..... 7	1	Reduced-Section Tension Test Specimen 14
4.2	Materials and Workmanship..... 8	2	Guided-Bend Test Specimen 14
4.3	Drawings..... 8	3	Jig for Guided-Bend Test 16
4.4	Calculations 9	4	Alternative Guided-Bend Wrap- around Jig..... 17
4.5	Protective Coating 9	5	Alternative Guided-Bend Roller Jig ... 18
4.6	Pipe Made to ASTM Requirements..... 9		
4.7	Fabricated Pipe 9		

Tables

1	Steel Plate, Sheet, or Coils for Fabricated Pipe	10
2	Guided-Bend Test Jig Dimensions	15

Kowsar San'at Espadana Co.

Foreword

This foreword is for information only and is not a part of AWWA C200.

I. Introduction.

I.A. *Background.* This standard covers butt-welded, straight seam or spiral seam steel pipe, 6 in. (150 mm) and larger, for transmission and distribution of water, including fabrication of pipe, requirements of welding operations, permissible variations of weight and dimensions, preparation of ends, fabrication of specials, inspection, and test procedures.

I.B. *History.* The first AWWA steel pipe standards issued were 7A.3 and 7A.4, published in 1940. Standard 7A.4 pertained to steel pipe smaller than 30 in. (750 mm) in diameter, and 7A.3 pertained to steel pipe 30 in. (750 mm) in diameter and larger. Subsequently, in recognition that some pipe used in water utility service was manufactured in steel mills rather than in a fabricator's shop, two new AWWA standards were issued in 1960. AWWA C201 replaced 7A.3 and pertained to all pipe, regardless of diameter, manufactured in a fabricator's shop from steel sheet or plate. The physical and chemical properties are properties of the sheet or plate from which the pipe is made. The properties are a function of the steel mill practice and are not affected significantly by fabricating procedures. AWWA C202 replaced 7A.4 and pertained to mill pipe, which is normally produced in a production pipe mill. The specified physical and chemical properties are those of the completed pipe. Physical testing is performed on the pipe rather than on the steel from which it originates. In many cases, the physical properties are significantly affected by the pipe-manufacturing procedure. AWWA C201 was revised in 1966, and AWWA C202 was revised in 1964. Both AWWA C201 and AWWA C202 were superseded by AWWA C200-75, approved by the AWWA Board of Directors on Jan. 26, 1975.

AWWA C200 includes all types and classes of steel pipe, 6 in. (150 mm) in diameter and larger, used in water utility service, regardless of the pipe manufacturing source. With adequate quality assurance, pipe manufactured in a fabricator's shop or in a steel pipe mill is suitable for water utility service. Pipe produced in a pipe mill according to one of the ASTM* standards cited in AWWA C200 will be subjected to specific quality-control procedures so that no further testing is required by AWWA C200.

* ASTM International, 100 Barr Harbor Drive, West Conshohocken, PA 19428.

Shop-fabricated pipe made from materials and in accordance with the quality-control measures stipulated in AWWA C200 will be of high quality.

By reference, AWWA C202 (which pertained to mill-type steel water pipe) included API* 5L and API 5LX pipe grades manufactured to API standards for high-pressure applications. With the inclusion of ASTM A570/A570M and ASTM A572/A572M high-strength steels in AWWA C200, API high-pressure pipe was omitted from AWWA C200 as being redundant. However, API 5L and API 5LX pipe grades fully met all requirements of AWWA C200 and could be used for water utility applications if dictated by availability or other economic considerations.

AWWA C200-75 introduced design criteria for determination of wall thickness to meet internal pressure conditions. This facilitated the selection of the optimum combination of thickness and material for steel pipe.

Revisions in ANSI/AWWA C200-86 included clarification of forming for lap joint ends and gasketed ends and testing of O-ring gaskets. ANSI/AWWA C200-91 was approved by the AWWA Board of Directors on June 23, 1991. ANSI/AWWA C200-97 was approved by the AWWA Board of Directors on Feb. 2, 1997. This edition was approved by the AWWA Board of Directors on June 12, 2005.

I.C. *Acceptance.* In May 1985, the US Environmental Protection Agency (USEPA) entered into a cooperative agreement with a consortium led by NSF International (NSF) to develop voluntary third-party consensus standards and a certification program for all direct and indirect drinking water additives. Other members of the original consortium included the American Water Works Association Research Foundation (AwwaRF) and the Conference of State Health and Environmental Managers (COSHEM). The American Water Works Association (AWWA) and the Association of State Drinking Water Administrators (ASDWA) joined later.

In the United States, authority to regulate products for use in, or in contact with, drinking water rests with individual states.[†] Local agencies may choose to impose requirements more stringent than those required by the state. To evaluate the health effects of products and drinking water additives from such products, state and local agencies may use various references, including

1. An advisory program formerly administered by USEPA, Office of Drinking Water, discontinued on Apr. 7, 1990.

*American Petroleum Institute, 1220 L Street N.W., Washington, DC 20005.

† Persons outside the United States should contact the appropriate authority having jurisdiction.

2. Specific policies of the state or local agency.
3. Two standards developed under the direction of NSF, NSF*/ANSI† 60, Drinking Water Treatment Chemicals—Health Effects, and NSF/ANSI 61, Drinking Water System Components—Health Effects.
4. Other references, including AWWA standards, *Food Chemicals Codex*,‡ *Water Chemicals Codex*‡ and other standards considered appropriate by the state or local agency.

Various certification organizations may be involved in certifying products in accordance with NSF/ANSI 61. Individual states or local agencies have authority to accept or accredit certification organizations within their jurisdiction. Accreditation of certification organizations may vary from jurisdiction to jurisdiction.

Annex A, “Toxicology Review and Evaluation Procedures,” to NSF/ANSI 61 does not stipulate a maximum allowable level (MAL) of a contaminant for substances not regulated by a USEPA final maximum contaminant level (MCL). The MALs of an unspecified list of “unregulated contaminants” are based on toxicity testing guidelines (noncarcinogens) and risk characterization methodology (carcinogens). Use of Annex A procedures may not always be identical, depending on the certifier.

AWWA C200 does not address additives requirements. Thus, users of this standard should consult the appropriate state or local agency having jurisdiction in order to

1. Determine additives requirements, including applicable standards.
2. Determine the status of certifications by all parties offering to certify products for contact with, or treatment of, drinking water.
3. Determine current information on product certification.

II. Special Issues.

II.A. *Advisory Information on Product Application.*

Basis of design. AWWA C200 pertains to the manufacture and testing of the steel-pipe cylinder. Overall design of steel pipelines is described in AWWA Manual M11, *Steel Water Pipe—A Guide for Design and Installation*. Coatings that protect against corrosion are referenced in Sec. 4.5.

*NSF International, 789 North Dixboro Road, Ann Arbor, MI 48113.

†American National Standards Institute, 25 West 43rd Street, Fourth Floor, New York, NY 10036.

‡Both publications available from National Academy of Sciences, 500 Fifth Street, N.W., Washington, DC 20001.

The determination of the wall thickness of steel pipe is affected by (1) internal pressure, including operating static and transient pressures; (2) external loads, including trench loading and earth fill; (3) special physical loading, such as continuous-beam loading with saddle supports or ring girders, vacuum conditions, type of joint used, and variations in operating temperature; and (4) practical considerations for handling, shipping, lining and coating, or similar operations.

The design techniques described in AWWA Manual M11 are used to determine minimum wall thicknesses of steel pipe. The purchaser may establish and specify the wall thickness determined to be satisfactory for all conditions, including internal pressure. Selection of design stresses and deflection limits should be made with regard to the properties of the lining and coating materials used. Alternatively, the purchaser may establish and specify the minimum wall thickness that will satisfy all conditions of external pressure and trench loadings and special physical loadings. The manufacturer is allowed to select materials and manufacturing processes within the limitations of this standard to produce pipe to the wall thickness required to additionally satisfy specified internal pressure. The purchaser should specify the internal design pressure and show the depth of cover over the pipe together with installation conditions. The manufacturer should select and provide pipe having a wall thickness that meets the requirements of the internal design pressure and external load design. This thickness should govern if it is greater than the minimum thickness specified by the purchaser. To meet the requirements of internal design pressure, the pipe wall thickness is determined by using the following formula:

$$t = \frac{PD}{2S} \quad (\text{Eq F.1})$$

Where:

t = design nominal wall thickness for the specified internal design pressures. Thickness and weight tolerances for pipe shall be governed by the requirements of the specification to which the plates or sheets are ordered (in. [mm])

P = internal design pressure (psi [kPa])—specified by the purchaser

D = outside diameter of the steel pipe cylinder (in. [mm])

S = design stress (psi [kPa]), not to exceed the purchaser-specified percentage of the minimum yield point of the steel selected by the manufacturer

Application. This standard describes the requirements for steel water pipe for use in water transmission and distribution under normal circumstances. It is the responsibility of the purchaser for each project to determine if any unusual circumstances related to the project require additional provisions that are not included in the standard. Such special conditions might affect design, manufacture, quality control, corrosion protection, or handling requirements.

Brittle fracture precautions. Under certain conditions where a restrained pipeline with welded lap joints has a pipe wall thickness in excess of ½ in. (12.7 mm) and the pipeline is to be operated at high stress levels at temperatures below 40°F (5°C), the purchaser should take precautions to prevent brittle fracture, which can result from a combination of notches and high stress concentrations at the joints. Precautions may include specifying a steel with adequate notch toughness and transition temperature and fabrication techniques that would reduce the possibility of brittle fracture.

Testing of special sections. Section 5.2.2.1 provides for nondestructive testing of the seams of specials. This testing should be adequate for normal conditions previously discussed under Application. Section 5.2.2.3 describes test methods that may be necessary if, in the opinion of the purchaser, unusually severe conditions exist, such as surge or transient pressures that cause stresses exceeding 75 percent of yield. This special testing must be specified by the purchaser.

Roundness of pipe. The roundness of pipe during handling, shipping, joint makeup, and backfilling should be covered in the purchaser's specifications. Pipe may have to be studded so it will remain round during transportation, installation, and backfilling.

III. Use of This Standard. It is the responsibility of the user of an AWWA standard to determine that the products described in that standard are suitable for use in the particular application being considered.

III.A. Purchaser Options and Alternatives. The purchaser should state whether compliance with NSF/ANSI 61, Drinking Water System Components—Health Effects, is to be required, in addition to the requirements of the Safe Drinking Water Act. The following items should be included in the the purchaser's specifications:

1. Standard used—that is, AWWA C200, Standard for Steel Water Pipe—6 In. (150 mm) and Larger, of latest revision.
2. A description or drawings indicating the diameter and total quantity of pipe required for each diameter.

3. Internal design pressure.
4. Design stress in the pipe wall at the specified internal design pressure as a percentage of the minimum yield point of the steel.
5. Minimum wall thickness required by considerations other than internal design pressure, such as allowable deflection; depth of cover; and, if aboveground, distance between supports.
6. Permeation requirements (Sec. 4.1).
7. Details of other federal, state, local, and provincial requirements (Sec. 4.2.1).
8. The drawings and calculations to be provided by the manufacturer if required (Sec. 4.3 and 4.4).
9. Protective coating (Sec. 4.5).
10. Toughness requirements (Footnote—Table 1).
11. Specification of pipe or steel if there is a preference (Sec. 4.6), or desired physical properties for “ordering to chemistry only” (Section 3 and Sec. 4.7.2).
12. Manual welding (Sec. 4.11.3).
13. Qualification code for manual welders if different from Sec. 4.11.3.1.
14. Length of pipe sections, random or specified lengths (Sec. 4.12.4).
15. Type of pipe ends (description or drawings) (Sec. 4.13).
16. Drawings of butt straps and instructions as to whether butt straps are to be supplied separately or attached to the pipe (Sec. 4.13.5).
17. Requirements for reports of tests of rubber-gasket materials (Sec. 4.13.6.3).
18. All special sections, indicating for each component part the dimensions or standard designation (Sec. 4.15) and the grade of material required (Sec. 4.16).
19. Instructions regarding inspection at place of manufacture (Sec. 5.1).
20. Minimum hydrostatic test pressure if different from Sec. 5.2.1.
21. Method of nondestructive testing to be used for special sections (Sec. 5.2.2.1) or, in the case of severe service conditions, the requirements for hydrostatic testing of special sections (Sec. 5.2.2.3).
22. Requirements for marking, line diagrams, or laying schedules (Sec. 6.1).
23. Special handling requirements and allowable out-of-roundness (Sec. 6.2).
24. Affidavit of compliance if required (Sec. 6.3).

III.B. *Modification to Standard.* Any modification to the provisions, definitions, or terminology in this standard must be provided in the purchaser’s specifications.

IV. Major Revisions. Major revisions made to the standard in this edition include the following:

1. Table 1 was revised to add ASTM A1011/A1011M and ASTM A1018/A1018M and to delete ASTM A570/A570M, ASTM A607/A607M, ASTM A907/A907M, ASTM A935/A935M, and ASTM A936/A936M.

2. Definitions for defect, discontinuity, CJP, CWI, MT, NDT, PT, RT, VT, and WPS were added.

V. Comments. If you have any comments or questions about this standard, please call the AWWA Volunteer and Technical Support Group at 303.794.7711, FAX at 303.795.7603, or write to the group at 6666 West Quincy Avenue, Denver, CO 80235-3098, or e-mail at standards@awwa.org.

Kowsar San'at Espadana Co.

This page intentionally blank.

Kowsar San'at Espadana Co.



AWWA Standard

Steel Water Pipe—6 In. (150 mm) and Larger

SECTION 1: GENERAL

Sec. 1.1 Scope

This standard describes electrically butt-welded straight-seam or spiral-seam pipe and seamless pipe, 6 in. (150 mm)* in nominal diameter and larger, for the transmission and distribution of water or for use in other water system facilities.

Sec. 1.2 Purpose

The purpose of this standard is to provide the minimum requirements for steel water pipe, 6 in. (150 mm) and larger, including materials and quality of work, fabrication of pipe, specials, and fittings.

Sec. 1.3 Application

This standard can be referenced in specifications for steel water pipe, 6 in. (150 mm) and larger. The stipulations of this standard apply when this document has been referenced and then only to steel water pipe, 6 in. (150 mm) and larger.

*Metric conversions given in this standard are direct conversions of US customary units and are not those specified in the International Organization for Standardization (ISO) standards.

SECTION 2: REFERENCES

This standard references the following documents. In their latest editions, they form a part of this standard to the extent specified within the standard. In any case of conflict, the requirements of this standard shall prevail.

ANSI* / ASME†—Boiler and Pressure Vessel Code, Section V.

ANSI/AWS‡ A3.0—Standard Welding Terms and Definitions Including Terms for Brazing, Soldering, Thermal Spraying and Thermal Cutting.

ANSI/AWS B2.1—Standard for Welding Procedure and Performance Qualification.

ANSI/AWS QC 1—Standard for AWS Certification of Welding Inspectors.

ANSI/AWWA C203—Coal-Tar Protective Coatings and Linings for Steel Water Pipelines—Enamel and Tape—Hot-Applied.

ANSI/AWWA C205—Cement-Mortar Protective Lining and Coating for Steel Water Pipe—4 In. (100 mm) and Larger—Shop-Applied.

ANSI/AWWA C208—Dimensions for Fabricated Steel Water Pipe Fittings.

ANSI/AWWA C209—Cold-Applied Tape Coatings for the Exterior of Special Sections, Connections, and Fittings for Steel Water Pipelines.

ANSI/AWWA C210—Liquid Epoxy Coating Systems for the Interior and Exterior of Steel Water Pipelines.

ANSI/AWWA C213—Fusion-Bonded Epoxy Coating for the Interior and Exterior of Steel Water Pipelines.

ANSI/AWWA C214—Tape Coating Systems for the Exterior of Steel Water Pipelines.

ANSI/AWWA C215—Extruded Polyolefin Coatings for the Exterior of Steel Water Pipelines.

ANSI/AWWA C216—Heat-Shrinkable Cross-Linked Polyolefin Coatings for the Exterior of Special Sections, Connections, and Fittings for Steel Water Pipelines.

ANSI/AWWA C217—Petrolatum and Petroleum Wax Tape Coatings for the Exterior of Connections and Fittings for Steel Water Pipelines.

* American National Standards Institute, 25 West 43rd Street, Fourth Floor, New York, NY 10036.

† ASME International, Three Park Ave., New York, NY 10016.

‡ American Welding Society, 550 N.W. LeJeune Rd., Miami, FL 33126.

ANSI/AWWA C218—Coating the Exterior of Aboveground Steel Water Pipe and Fittings.

ANSI/AWWA C222—Polyurethane Coatings for the Interior and Exterior of Steel Water Pipe and Fittings.

ANSI/AWWA C224—Nylon-11-Based Polyamide Coating System for the Interior and Exterior of Steel Water Pipe, Connections, Fittings, and Special Sections.

ANSI/AWWA C225—Fused Polyolefin Coating Systems for the Exterior of Steel Water Pipelines.

ANSI/AWWA C602—Cement-Mortar Lining of Water Pipelines in Place—4 In. (100 mm) and Larger.

ASME—Boiler and Pressure Vessel Code, Sec. IX.

ASTM A36/A36M—Standard Specification for Carbon Structural Steel.

ASTM A53—Standard Specification for Pipe, Steel, Black and Hot-Dipped, Zinc-Coated, Welded and Seamless.

ASTM A134—Standard Specification for Pipe, Steel, Electric-Fusion (Arc)-Welded (Sizes NPS 16 and over).

ASTM A135—Standard Specification for Electric-Resistance-Welded Steel Pipe.

ASTM A139/A139M—Standard Specification for Electric-Fusion (Arc)-Welded Steel Pipe (NPS 4 and over).

ASTM A283/A283M—Standard Specification for Low and Intermediate Tensile Strength Carbon Steel Plates.

ASTM A370—Standard Test Methods and Definitions for Mechanical Testing of Steel Products.

ASTM A568/A568M—Standard Specification for Steel, Sheet, Carbon and High-Strength, Low-Alloy, Hot-Rolled and Cold-Rolled, General Requirements for.

ASTM A572/A572M—Standard Specification for High-Strength Low-Alloy Columbium-Vanadium Structural Steel.

ASTM A635/A635M—Standard Specification for Steel, Sheet and Strip, Heavy-Thickness Coils, Carbon, Hot-Rolled.

ASTM A673/A673M—Standard Specification for Sampling Procedure for Impact Testing of Structural Steel.

ASTM A1011/A1011M—Standard Specification for Steel, Sheet and Strip, Hot-Rolled, Carbon, Structural, High-Strength Low-Alloy and High-Strength Low-Alloy with Improved Formability.

ASTM A1018/A1018M—Standard Specification for Steel, Sheet and Strip, Heavy Thickness Coils, Hot-Rolled, Carbon, Structural, High-Strength Low-Alloy, Columbium or Vanadium, and High-Strength Low-Alloy with Improved Formability.

ASTM D297—Standard Test Methods for Rubber Products—Chemical Analysis.

ASTM D395—Standard Test Methods for Rubber Property—Compression Set.

ASTM D412—Standard Test Methods for Vulcanized Rubber and Thermoplastic Rubbers and Thermoplastic Elastomers—Tension.

ASTM D573—Standard Test Method for Rubber-Deterioration in an Air Oven.

ASTM D2240—Standard Test Method for Rubber Property—Durometer Hardness.

ASTM E340—Standard Test Method of Macroetching Metals and Alloys.

AWWA Manual M11—*Steel Water Pipe—A Guide for Design and Installation.*

SECTION 3: DEFINITIONS

The following definitions shall apply in this standard:

1. *Bevel*: The angle formed between the prepared edge of a pipe end and a plane perpendicular to the surface of the pipe. Bevels are generally used for butt-joint welding of pipe ends.
2. *Check analysis*: The chemical analysis taken from the skelp, plate, or pipe.
3. *CJP*: Complete joint penetration.
4. *Constructor*: The party that provides the work and materials for placement or installation.
5. *Coupon (weld coupon)*: A piece of steel from which weld test specimens are cut. The coupon shall be cut from the pipe at a location that includes a section of the weld. As an alternative, the coupon may consist of a pair of test plates made from metal of the same specifications and thicknesses as the pipe wall. The test plates should be prepared for welding and attached to a pipe shell being welded at the end of a longitudinal joint so that the edges to be welded in the test plates are a continuation of and to the corresponding edges of the longitudinal joint. The pair of plates is made into a single weld test specimen by having the weld metal deposited in the test plates continuously with the weld metal deposited in the longitudinal joint by the same technique.

6. *CWI*: Certified welding inspector.
7. *Defect*: A discontinuity or discontinuities that by nature or accumulated effect (for example, total crack length) render a part or product unable to meet the minimum applicable acceptance standards or specifications. This term designates rejectability.
8. *Discontinuity*: An interruption of the typical structure of a weldment such as lack of homogeneity in the mechanical or metallurgical or physical characteristics of material or weldment. A discontinuity is not necessarily a defect.*
9. *Electrically butt-welded pipe*: Straight-seam or spiral-seam resistance-welded or fusion-welded pipe.
10. *Fillet weld*: A weld of approximately triangular cross section, the throat of which lies in a plane disposed approximately 45° with regard to the surface of the parts joined. (The size of the fillet weld is expressed in terms of the width, in inches or millimeters, of one of its adjacent fused legs; the shorter leg, if unequal.)
11. *Flame cutting*: The process of severing metal by means of a gas flame.
12. *Fusion welding*: The melting together of filler metal and base metal, or melting of base metal only, which results in coalescence.
13. *Girth weld*: A circumferential welded seam lying in one plane, used to join sections into lengths of straight pipe or to join pieces of mitered pipe to form fabricated special sections and fittings.
14. *Internal design pressure*: The maximum sustained internal pressure to which the pipe is subjected under normal operating conditions. Generally, the internal design pressure for each pipe or portion of the pipeline shall be based on the operating pressure established by the hydraulic gradient or static head specified by the purchaser, whichever results in the greater pressure. In addition, transient pressures should be considered by the purchaser in defining the internal design pressure.
15. *Ladle analysis*: The chemical analysis taken at the time the steel is cast.
16. *Lap joint*: A circumferential joint in which one of the members joined overlaps the other.
17. *Longitudinal weld*: A welded seam parallel to the axis of the pipe.
18. *MT*: Magnetic particle testing.

*“Fundamentals of Weld Discontinuities and Their Significance,” Welding Research Council, Bulletin 295, C.D. Lundeen.

19. *Manufacturer:* The party that manufactures or produces materials or products.

20. *Miter:* The angle included between the cut of a pipe end and a line drawn perpendicular to the longitudinal axis of the pipe. Miters are used in fabricating elbows and to facilitate pipe laying at changes in horizontal or vertical alignment.

21. *NDT:* Nondestructive testing.

22. *Nominal diameter or size:* The commercial designation or dimension by which pipe is designated for simplicity.

23. *Nominal wall thickness:* The thickness designation as distinguished from the actual or measured thickness.

24. *Nominal weight per unit length (for bare pipe):* The theoretical weight per unit length, calculated from the nominal wall thickness, as distinguished from the actual or measured weight per unit length of the finished pipe. Unit weights of 0.2836 lb/in.³ (7,850 kg/m³) for steel sheet and 490 lb/ft³ (7,850 kg/m³) for steel plate shall be used when calculating weight per unit length, in ft (m).

25. *Order to chemistry:* A procedure whereby a manufacturer specifies chemical elements to be used in making the steel, but omits the physical properties. It is the manufacturer's responsibility to perform, or have performed, physical tests and to provide proof of physical properties to the satisfaction of the purchaser.

26. *PT:* Liquid penetrant testing.

27. *Plain-end pipe:* Pipe not threaded, belled, or otherwise given a special end configuration.

28. *Purchaser:* The person, company, or organization that purchases any materials or work to be performed.

29. *RT:* Radiographic testing.

30. *Random lengths:* Pipe lengths as produced in a pipe mill, to which no special treatment is given to make the lengths uniform. Random lengths shall be as described in Sec. 4.12.4.2.

31. *Reinforcement of weld:* Weld metal on the face of a weld in excess of the metal necessary for the specified weld size.

32. *Resistance-welded pipe:* Pipe having a longitudinal or spiral butt joint that is produced by the heat obtained from resistance to the flow of electric current across the joint and by the application of pressure.

33. *Root:* That portion of a joint to be welded where the members approach closest to each other. In cross section, the root of a joint may be a point, a line, or an area.

34. *Seamless pipe:* Pipe without welds, made from solid ingots, blooms, billets, or round bars that have been hot-pierced and then brought to the desired size by hot rolling, hot drawing, or a combination of both.

35. *Special section:* Any piece of pipe other than a normal straight section. This includes but is not limited to elbows, manhole sections, reducers, adapter sections with special ends, and other nonstandard sections.

36. *Specified lengths:* Sections of finished pipe, the length dimensions of which do not vary from a fixed figure specified by the purchaser by more than the tolerance set forth in this standard.

37. *Spiral-seam welded pipe:* Pipe in which the line of the seam forms a helix on the barrel of the pipe.

38. *Straight-seam welded pipe:* Pipe in which the line of the seam is parallel to the axis of the pipe.

39. *Supplier:* The party that supplies material or services. A supplier may or may not be the manufacturer.

40. *UT:* Ultrasonic testing.

41. *VT:* Visual testing or inspection.

42. *WPS:* Welding procedure specification.

43. *Welded butt joints:* A weld, the throat of which lies in a plane disposed approximately 90° with regard to the surface of at least one of the parts joined. The size of the butt weld shall be expressed in terms of its net throat dimensions, in inches (millimeters), excluding weld metal above plate surface. A double-welded joint is one in which the filler metal is added to both sides. A single-welded butt joint is one in which the filler metal is added to one side only. All welded butt joints shall be full-penetration butt welds as determined by the etch test (Sec. 4.11.5.4).

SECTION 4: REQUIREMENTS

Sec. 4.1 Permeation

The selection of materials is critical for water service and distribution piping in locations where there is likelihood the pipe will be exposed to significant

concentrations of pollutants composed of low molecular weight petroleum products or organic solvents or their vapors. Documented research has shown that pipe materials such as polyethylene, polybutylene, polyvinyl chloride, and asbestos cement, and elastomers, such as used in jointing gaskets and packing glands, are subject to permeation by lower molecular weight organic solvents or petroleum products. If a water pipe must pass through such a contaminated area or an area subject to contamination, consult with the manufacturer regarding permeation of pipe walls, jointing materials, and so forth, *before* selecting materials for use in that area.

Sec. 4.2 Materials and Workmanship

4.2.1 *General.* All material provided and all work completed shall meet the requirements of this standard.

Materials shall comply with the requirements of the Safe Drinking Water Act and other federal requirements.

4.2.2 *Discontinuities.* The finished pipe shall be free from unacceptable discontinuities. Discontinuities in seamless pipe or in the parent metal of welded pipe shall be considered unacceptable when the depth of the discontinuity is greater than 12.5 percent of the nominal wall thickness. Cracks, sweats, and leaks in welds shall not be acceptable.

Inspection shall be 100 percent visual inspection (VT) per ANSI/AWS D1.1 Table 6.1 for statically loaded nontubular connections by trained personnel. Additional inspection must be specified by the purchaser.

4.2.3 *Repair of discontinuities.* The repair of discontinuities shall be permitted. Repairs shall conform to the following requirements:

1. The discontinuity shall be removed and the cavity thoroughly cleaned.
2. The repair weld shall be made by automatic welding or manual welding by a welder qualified in accordance with Sec. 4.11.2.1 or Sec. 4.11.3.1.
3. All repairs shall be tested in accordance with Sec. 5.2.1 or Sec. 5.2.2.

Sec. 4.3 Drawings

If drawings are required, they shall be subject to acceptance by the purchaser.

Sec. 4.4 Calculations

If the manufacturer is required to determine the wall thickness, the manufacturer's calculations of wall thickness shall be submitted to and accepted by the purchaser.

Sec. 4.5 Protective Coating

The pipe and special sections may be provided with a coating or lining conforming to ANSI/AWWA C203, ANSI/AWWA C205, ANSI/AWWA C209, ANSI/AWWA C210, ANSI/AWWA C213, ANSI/AWWA C214, ANSI/AWWA C215, ANSI/AWWA C216, ANSI/AWWA C217, ANSI/AWWA C218, ANSI/AWWA C222, ANSI/AWWA C224, ANSI/AWWA C225, ANSI/AWWA C602, or some combination of these systems, or an equally effective system as those listed, or as otherwise specified by the purchaser.

Sec. 4.6 Pipe Made to ASTM Requirements

If the pipe is to be manufactured to meet the requirements of one or more of the ASTM specifications listed in Sec. 4.9, Charpy values as noted in Table 1 may apply, and the grades of pipe shall be

1. For ASTM A53, Type E or S.
2. For ASTM A134, any of the steels listed in Table 1.
3. For ASTM A135, all grades.
4. For ASTM A139, all grades.

Sec. 4.7 Fabricated Pipe

4.7.1 *General.* When the pipe is to be fabricated to meet the requirements of Sec. 4.10 through Sec. 4.13, the plate, sheet, or coil shall be selected from Table 1. The material shall be manufactured to killed fine-grain practice. When specifically referenced as a material specification for pipe fabrication, this practice shall also apply to ASTM A139 (Sec. 4.6).

4.7.2 *Orders to chemistry only.* As an alternative, the manufacturer may order material to chemistry only and provide the purchaser with certified test reports from a laboratory approved by the purchaser showing that the physical properties of the applicable sheet or plate specification are met.

Table 1 Steel plate, sheet, or coils for fabricated pipe

Specification	Grade	Minimum Yield Point <i>psi (MPa)</i>	
	Steel Plate		
ASTM A36/A36M		36,000 (248)	
ASTM A283/A283M	C	30,000 (207)	
	D	33,000 (228)	
ASTM A572/A572M	42	42,000 (290)	
	50	50,000 (345)	
ASTM A1011/1011M	Structural Steel (SS)		
	30	30,000 (207)	
	33	33,000 (228)	
	36	36,000 (248)	
	40	40,000 (276)	
	45	45,000 (310)	
	50	50,000 (345)	
	55	55,000 (380)	
	High-Strength—Low-Alloy Steel (HSLAS)		
	45	45,000 (310)	
	50	50,000 (345)	
	55	55,000 (380)	
	High-Strength—Low-Alloy Steel With Improved Formability (HSLAS-F)		
	50	50,000 (345)	
ASTM A1018/1018M	Structural Steel (SS)		
	30	30,000 (207)	
	33	33,000 (228)	
	36	36,000 (248)	
	40	40,000 (276)	
		High-Strength—Low-Alloy Steel (HSLAS)	
		45	45,000 (310)
		50	50,000 (345)
	55	55,000 (380)	
	High-Strength—Low-Alloy Steel With Improved Formability (HSLAS-F)		
	50	50,000 (345)	

NOTE: For pipelines more than ½ in. (13 mm) in wall thickness, a Charpy V-notch (CVN) value of 25 lbf-ft (33.9 N·m) average at 30°F (1°C), transverse specimen, heat-lot testing, for the steel may be specified. CVN specimens shall be prepared in accordance with ASTM A370. Heat lot testing for plate is as specified in ASTM A673. Heat lot testing for coils is two coils per heat, outerwrap only. Filler material shall meet the same toughness properties as the base metal. This is particularly important in restrained pipelines with welded lap joints operating at temperatures below 40°F (4°C).

4.7.3 *Determination of thickness.* Plate, sheet, and coil shall be ordered to the thickness determined considering all pertinent design factors. The maximum allowable thickness variation for plate, sheet, or coil shall be 0.010 in. (0.254 mm) less than the ordered thickness. For sheet, the maximum allowable thickness variations shall be as tabulated in ASTM A568/A568M for thicknesses up to 0.230 in. (5.84 mm) or ASTM A635/A635M for larger thicknesses, or 0.010 in. (0.25 mm), whichever is less.

Sec. 4.8 Selection of Materials

If the purchaser fails to specify the type of pipe or steel as indicated in Sec. III.A, item 11, of the foreword of this standard, the manufacturer shall, with the purchaser's approval, select the type of pipe and steel, including its physical and chemical properties, in accordance with Sec. 4.6, 4.7, and 4.8.

Sec. 4.9 General Requirements for Fabrication of Pipe

Pipe produced in a pipe mill according to one of the cited ASTM standards shall be subjected to ANSI/AWWA C200 quality-control procedures. Such pipe shall be manufactured to meet the requirements of ASTM A53, ASTM A134, ASTM A135, or ASTM A139/A139M using one of the grades listed in Sec. 4.6 of this standard. All of the above shall be fabricated in compliance with Sec. 4.10 and Sec. 4.11 and a quality-assurance program (Sec. 5.1.1).

Sec. 4.10 Fabrication of Pipe

The longitudinal edges of the sheet or plate shall be shaped by press or by rolling to the true pipe radius. Hammering the edges to shape shall not be permitted. The plate or sheet shall then be properly formed and may be tacked prior to welding. The weld shall be of reasonably uniform width and height for the entire length of the pipe, and it shall be made by automatic means, except that, by agreement between the purchaser and the manufacturer, manual welding by qualified procedure and welders shall be acceptable.

4.10.1 *Weld seams.* All spiral, longitudinal, and girth seams used in the manufacture of the pipe shall be complete joint penetration (CJP) welded butt joints. For pipe wall thicknesses (t) of $\frac{3}{8}$ in. (9.5 mm) or less, the maximum radial offset (misalignment) shall not exceed $0.1875t$ or $\frac{1}{16}$ in. (1.6 mm), whichever is larger. For

values of t greater than $3/8$ in. (9.5 mm), the maximum radial offset shall not exceed $0.1875t$ or $1/8$ in. (3.2 mm), whichever is smaller.

Offset shall be measured with commercially available equipment, such as a Cambridge-type gauge or a V-wack gauge, and shall be measured from both sides of the weld. The average of the two values should be used as the offset value. Repair of out-of-tolerance pipe may be made on localized areas (with offset not to exceed $0.3t$ with $3/8$ -in. [9.5-mm] maximum for a length of 8 in. [203 mm]) by adding sufficient weld metal to provide a 4:1 transition. All other areas out of tolerance may be repaired by removing the weld metal, realigning the material, and rewelding in accordance with welding requirements of this standard. The manufacturer shall take all reasonable precautions to minimize recurring imperfections, damage, and discontinuities.

4.10.2 *Joining of lengths in the shop.* Unless otherwise specified by the purchaser, lengths of pipe may be joined in the shop by using a lap joint, subject to the tolerances set forth in Sec. 4.13

Sec. 4.11 Requirements for Welding Operations

The pipe manufacturer shall request information regarding welding procedures from the plate or sheet manufacturer if the pipe manufacturer lacks experience in welding the material selected. All welding shall be performed in accordance with the sheet or plate manufacturer's recommendations for preheating and the type of electrode to be used.

4.11.1 *End welding.* All end welding of longitudinal seams of fusion-welded pipe, if not done by automatic submerged-arc or automatic shielded-arc welding, shall be done by an operator qualified in accordance with Sec. 4.11.3.1.

4.11.2 *Automatic welding.* All longitudinal, spiral, and girth seams of straight pipe sections and special sections, when practicable, shall be welded with an automatic welding machine. On request, sample welds shall be submitted to the purchaser for testing.

4.11.2.1 *Qualification.* Automatic welding operators and procedures shall be qualified under Section IX of the ANSI/ASME Boiler and Pressure Vessel Code, under ANSI/AWS B2.1, or under any other code mutually agreed on between the purchaser and manufacturer.

4.11.3 *Manual welding.* Manual welding of girth seams shall be permitted on straight pipe sections consisting of more than one full length (random or

specified) when agreed on by the purchaser and manufacturer. Manual welding of special sections and fittings shall be permitted when it is impractical to use an automatic welding machine. On straight pipe sections, manual welding shall be permitted only for tack welding of coils and plates during the continuous pipe-making process, in making a weld on the inside of the pipe, in rewelding and repairing structural discontinuities in the plate and automatic machine welds, and as otherwise permitted in this standard (Sec. 4.10).

4.11.3.1 *Qualification.* Manual-welding operators and procedures shall be qualified under Section IX of the ANSI/ASME Boiler and Pressure Vessel Code, under ANSI/AWS B2.1, or under any other code acceptable to the purchaser and the manufacturer.

4.11.4 *Welding operator tests.* The purchaser shall have the right to call for and witness the making of weld tests by any welding operator, in accordance with Sec. 4.11.5, at any time the purchaser believes satisfactory welding is not being performed.

4.11.5 *Test of production welds.* Welding performance shall be inspected during production in accordance with Sec. 4.11.

4.11.5.1 *Weld-test specimens.* The weld-test specimens shall be taken perpendicularly across the weld or from test plates made of material used in the manufacture of the pipe. Test plates shall be welded using the same procedure, operator, and equipment and in sequence with the welding of the longitudinal joints in the pipe. The test plates shall have the weld approximately in the middle of the specimen. The specimens shall be straightened and tested at room temperature.

4.11.5.2 *Reduced-section tension specimens.* Two reduced-section tension specimens made in accordance with Figure 1 shall test at a tensile strength not less than 100 percent of the minimum specified tensile strength of the base material used.

4.11.5.3 *Bend-test specimens.* Two bend-test specimens shall be prepared in accordance with Figure 2 and shall withstand a 180° bend in a jig in accordance with Figures 3, 4, or 5. When making the guided-bend tests, one specimen shall be bent so that the face representing the inside of the pipe is on the inside of the test bend. The second bend test shall be made so that the face of the specimen representing the inside of the pipe is on the outside of the test bend. A guided-bend test specimen shall be considered as having passed if (1) no crack or other open discontinuity exceeding $\frac{1}{8}$ in. (3.2 mm) measured in any direction is present in the weld metal or

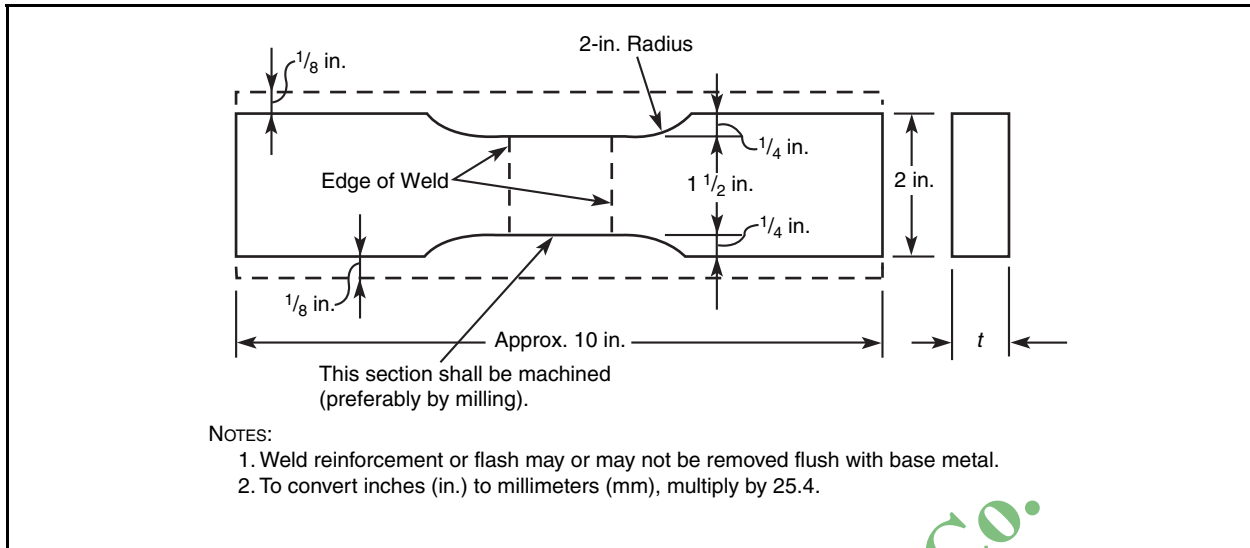

Figure 1 Reduced-section tension test specimen

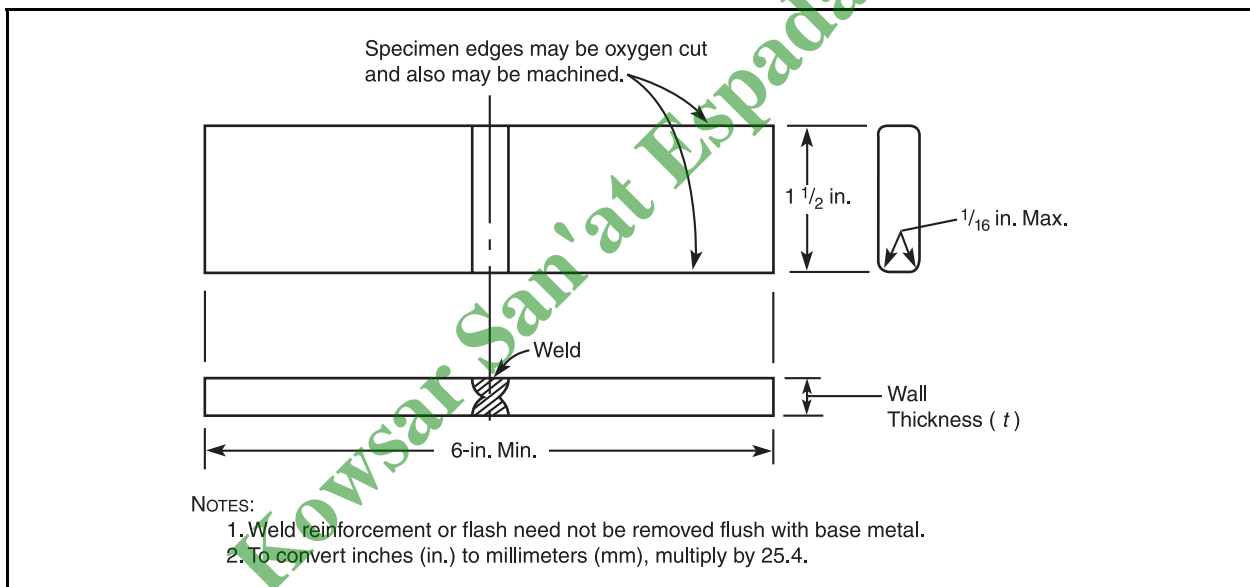

Figure 2 Guided-bend test specimen

between the weld and base material after the bending; or (2) for electric-resistance welded straight seam pipe, 16 in. (400 mm) and smaller in diameter, two face bends or a set of 0° and 90° flattening tests (ASTM A135/A135M, Section 9) may be performed in lieu of the above bend tests.

4.11.5.4 Etching tests. Etching tests for complete joint penetration (CJP)

Table 2 Guided-bend test jig dimensions*

	Specified Minimum Yield Strength— <i>psi</i>			
	Up to 42,000	42,000	45,000	50,000–55,000
Radius of male member, R_A	$2t^\dagger$	$3t$	$3\frac{1}{2}t$	$4t$
Radius of female member, R_B	$3t + \frac{1}{16}$ in.	$4t + \frac{1}{16}$ in.	$4\frac{1}{2}t + \frac{1}{16}$ in.	$5t + \frac{1}{16}$ in.
Width of male member, A	$4t$	$6t$	$7t$	$8t$
Width of groove in female member, B	$6t + \frac{1}{8}$ in.	$8t + \frac{1}{8}$ in.	$9t + \frac{1}{8}$ in.	$10t + \frac{1}{8}$ in.

*For intermediate grades of pipe, the above dimensions of the bending jig shall conform to those shown for the next lower grade or shall be proportional thereto.

† t = specified wall thickness of the pipe.

NOTES:

1. To convert inches (in.) to millimeters (mm), multiply by 25.4.
2. To convert pounds per square inch (psi) to kilopascals (kPa), multiply by 6.895.

butt joint production welds shall be done on normal production weld tests. CJP is defined in ANSI/AWS A3.0. Verification of CJP shall be done by means of a macroetch of the joint weld cross section on the same frequency as for the guided-bend test. Macroetch technique shall be as prescribed in ASTM E340.

4.11.5.5 Defective test specimens. If any test specimen shows defective machining or develops flaws not associated with the welding, it may be discarded and another specimen substituted.

4.11.6 *Frequency of production weld tests.* There shall be at least one set of weld-test specimens taken of each size, grade, and wall thickness from work performed by each welding machine and each operator at a minimum of every 3,000 ft (915 m) of pipe except as required under Sec. 4.11.4.

4.11.7 *Retests.* If any specimen tested in accordance with Sec. 4.11.5 fails to meet the specified requirements, retests of two additional specimens from the same lot of pipe shall be made, each of which shall meet the requirements specified. If such specimens conform to the specified requirements, all lengths from the lot shall be accepted, except the length initially selected for testing. If any of the retests fail to conform to the requirements, the entire lot shall be rejected, or test specimens may be taken from each untested pipe length at the manufacturer's option, and each specimen shall meet the requirements specified, or that pipe shall be rejected. The

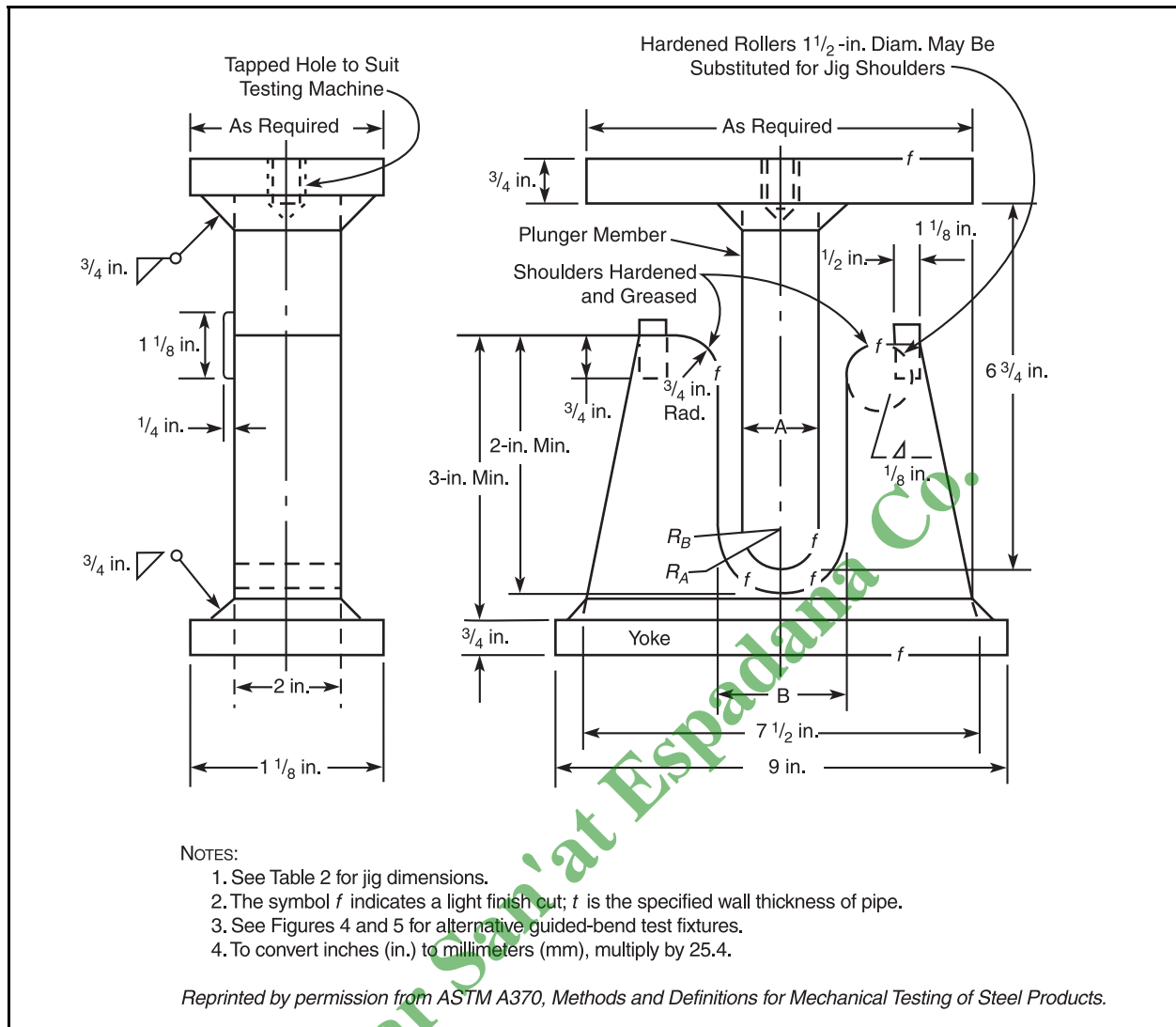

Figure 3 Jig for guided-bend test

manufacturer may also elect to retest any length that has failed to pass the test by cropping back and cutting two additional specimens from the same end. If the requirements of the original test are met by both of these additional tests, that length shall be acceptable. The maximum size for a lot will be the pipe produced requiring no more than one set of weld tests as defined in Sec. 4.11.6.

4.11.8 *Weld repair.* Weld repair may be made by any procedures mutually agreed on by the manufacturer and purchaser.

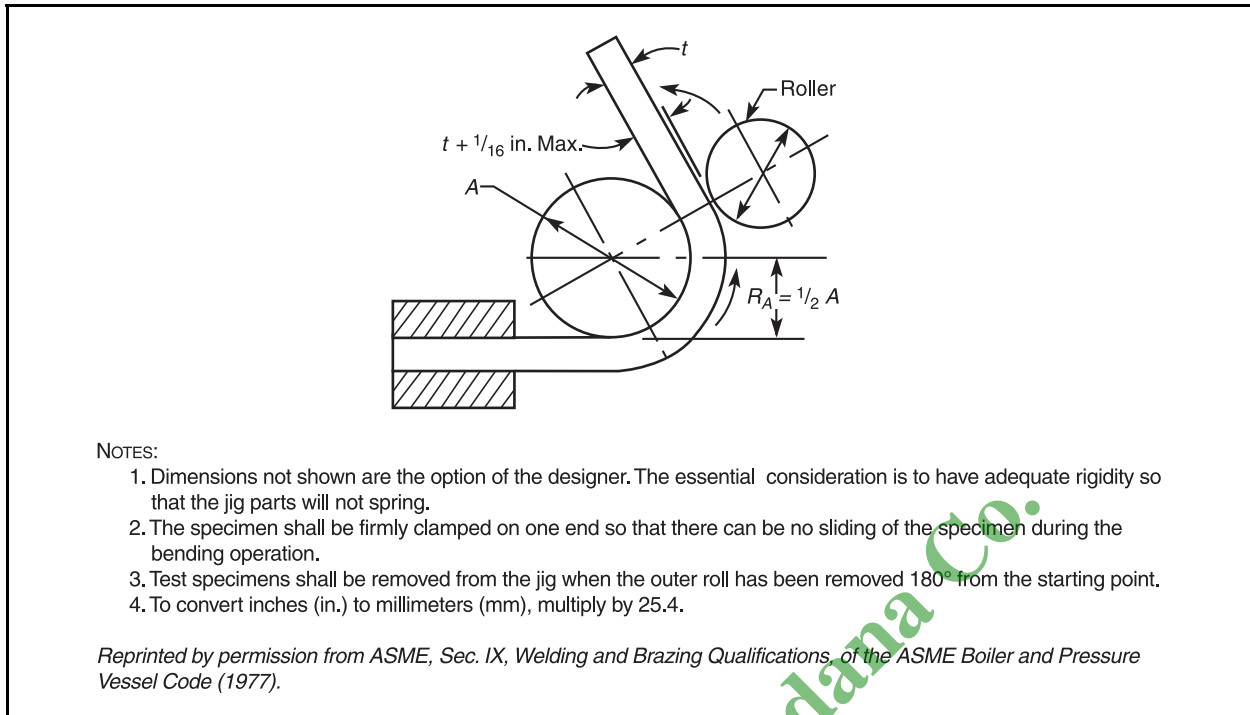

Figure 4 Alternative guided-bend wraparound jig

Sec. 4.12 Permissible Variations in Weights and Dimensions

4.12.1 *Thickness and weights.* Unless specified by the purchaser, the wall thickness and weight tolerances for welded pipe shall be governed by the requirements of the specifications to which the plates or sheets are ordered.

4.12.2 *Circumference.* The pipe shall be substantially round. The outside circumference of the pipe shall not vary more than ± 1.0 percent but not to exceed $3/4$ in. (19 mm) from the nominal outside circumference based on the diameter specified, except that the circumference at ends shall be sized, if necessary, to meet the requirements of Sec. 4.13.

4.12.3 *Straightness.* Finished pipe shall not deviate by more than $1/8$ in. (3.2 mm) from a 10-ft (3-m) long straightedge held against the pipe.

4.12.4 *Lengths.* Pipe lengths shall be supplied in accordance with the following:

4.12.4.1 *Specified.* Specified lengths shall be provided with a tolerance of ± 2 in. (± 51 mm). This tolerance does not apply to the shorter lengths from which test coupons have been cut.

4.12.4.2 *Random.* Random lengths shall be provided in lengths averaging

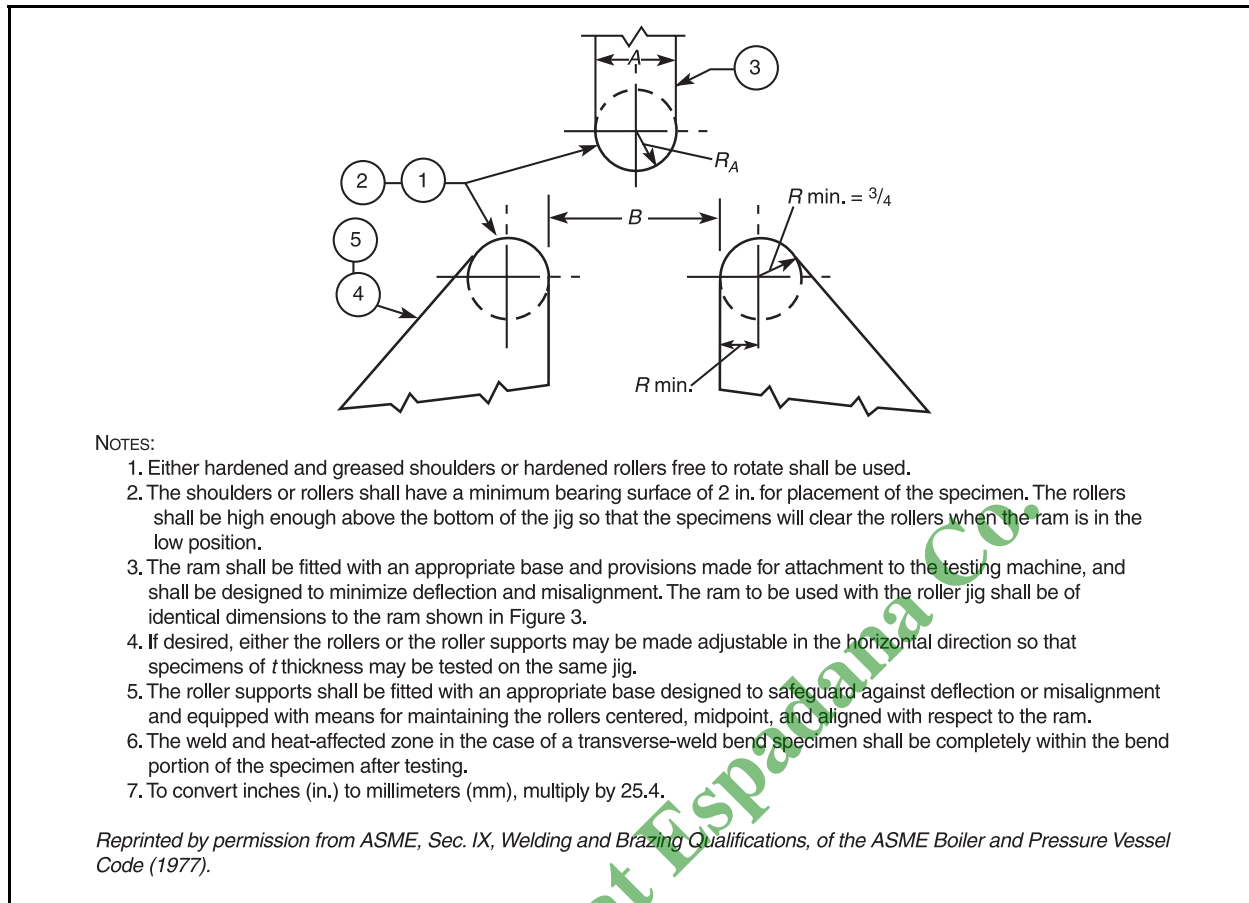

Figure 5 Alternative guided-bend roller jig

29 ft (8.84 m) or more, with a minimum length of 20 ft (6.10 m), but not more than 5 percent of the random lengths shall be less than 25 ft (7.62 m).

4.12.4.3 Girth welds. Pipe lengths containing girth welds shall be permitted by agreement between the manufacturer and the purchaser (Sec. 4.10.1). Tests of these welded joints shall be made in accordance with the production weld tests set forth in Sec. 4.11.

Sec. 4.13 Preparation of Ends

Ends of pipe sections shall be of the type specified by the purchaser. All pipe ends shall be smooth and free of notches, weld spatter, and burrs.

4.13.1 *Ends for mechanically coupled field joints.* Ends for mechanically coupled field joints shall be as specified by the purchaser and shall be plain, grooved, or banded. The outside surfaces of ends of plain-end pipe shall be free from surface

discontinuities and shall have the longitudinal or spiral welds ground flush with the plate surface for a sufficient distance from the ends to permit the coupling gaskets to form a watertight seal against the pipe wall. Grooved or banded ends shall be prepared to fit the type of mechanical coupling to be used.

4.13.2 *Ends for lap joints for field welding.* The bell ends shall be formed by expanding with segmental dies on a hydraulic expander, pressing on a plug die, or by rolling. After forming, the minimum radius of the curvature of the bell end at any point shall not be less than 15 times the nominal thickness of the steel shell. Bell ends shall be formed in a manner to avoid impairment of the mechanical properties of the steel shell. Joints shall permit a lap, when the joint is assembled, of at least 1 in. (25 mm). The longitudinal or spiral weld on the inside of the bell end and the outside of the spigot end on each section of pipe shall be ground flush with the plate surface. The inside edge of the bell and the outside edge of the spigot shall be scarfed or lightly ground to remove sharp edges and burrs.

4.13.3 *Plain-end pipe.* Pipe shall be provided with a plain right-angle cut. All burrs at the ends of the pipe shall be removed.

4.13.4 *Beveled ends for field butt welding.* If pipe is specified to have the ends beveled for field butt welding of circumferential joints, the ends shall be beveled to an angle of 30°, measured from a line drawn at right angles to the axis of the pipe, with a tolerance of +5°, -0°, and with a width of root face (or flat at the end of the pipe) of $1/16$ in. \pm $1/32$ in. (1.6 mm \pm 0.8 mm). Other bevel angles may be used if prior approval between purchaser and constructor is obtained. Bevel angles shall be in accordance with approved welding procedure specifications (WPS).

4.13.5 *Ends fitted with butt straps for field welding.* Ends of pipe to be fitted with butt straps for field welding shall comply with the requirements of the purchaser. Butt straps may be made in halves or as complete cylinders. They shall be welded to the pipe by the manufacturer or shipped separately, as specified by the purchaser. The weld at the pipe ends and inside the butt straps shall be ground flush with the plate surfaces for a distance sufficient to facilitate installing the butt strap.

4.13.6 *Bell-and-spigot ends with rubber gasket.* Bell-and-spigot ends shall be designed so that when the joint is assembled, it will be self-centered, and the gasket will be restrained or confined to an annular space so that the gasket cannot be displaced by movement of the pipe or hydrostatic pressure. When the joint is completed, compression of the gasket shall not be dependent on water pressure in the

pipe and shall be adequate to ensure a watertight seal when subjected to the purchaser's conditions of service.

NOTE: AWWA Manual M11 shows several types of bell-and-spigot joints with rubber gaskets. Other types are available from various pipe manufacturers.

4.13.6.1 Fabrication. Bell-and-spigot ends may be formed integrally with the steel cylinder or may be fabricated from separate plates, sheets, or special sections for attachment to pipe ends. Bell ends formed integrally with the cylinder shall be shaped either by pressing over a machined swage or die or by sizing with an internal expander. Spigot ends may be formed integrally with the steel cylinder by rolling with suitable equipment or by welding a preformed shape or flat bars to the spigot end of the pipe to form a groove of the proper configuration. All welds on the inside of the bell and outside of the spigot shall be ground flush with the plate surface for a distance not less than the depth of insertion.

4.13.6.2 Rubber gaskets. The manufacturer shall supply a continuous rubber gasket for each bell-and-spigot joint. The size and shape of the gasket cross section shall be such that, in its final installed position, continuous contact with both the bell and the spigot shall be maintained and the gasket shall be under sufficient compressive stress to ensure a watertight seal under all permissible conditions of joint assembly. Gaskets shall be of sufficient volume to fill the recess provided when the pipe joint is assembled. The gasket shall be the sole element depended on to make the joint watertight. Gaskets shall have smooth surfaces free from pitting, blisters, porosity, and other imperfections. The rubber compound shall contain not less than 50 percent by volume of first-grade synthetic rubber or synthetic-rubber blends. The remainder of the compound shall consist of pulverized fillers free from rubber substitutes, reclaimed rubber, and deleterious substances. The compound shall contain 10 to 20 parts per hundred of type SBR-1500 additive (styrene butadiene rubber). The compound shall meet the following physical requirements when tested in accordance with the indicated ASTM standards:

1. *Tensile strength:* 2,300 psi (15.86 MPa) minimum (ASTM D412).
2. *Elongation at rupture:* 350 percent minimum (ASTM D412).
3. *Specific gravity:* Consistent within ± 0.05 and in the range of 0.95–1.45 (ASTM D297).
4. *Compression set:* 20 percent maximum. The compression set determination shall be made in accordance with ASTM D395, except that the disc shall be a $1/2$ -in. (12.7-mm) thick section of the rubber gasket.

5. *Tensile strength after aging:* After being subjected to an accelerated aging test for 96 hr in air at 158°F (70°C) in accordance with ASTM D573, reduction in tensile strength shall not exceed 20 percent of the initial value.

6. *Shore durometer:* The shore-durometer hardness shall be in the range of 50–65 and shall be within ± 5 points. Values shall be determined in accordance with ASTM D2240, with the exception of Section 4 thereof. The determination shall be taken directly on the gasket.

4.13.6.3 Testing and certification. Rubber gaskets shall be tested to ensure that the material is fully cured and homogeneous, and that the gasket cross section contains no voids or physical defects that will impair its ability to maintain compressive strength and provide the necessary volume, as designed. The supplier shall provide test results showing that the material meets the requirements of Sec. 4.13.6.2 and 4.13.6.3.

4.13.7 *Plain ends fitted with flanges.* Ends to be fitted with flanges shall have the longitudinal or spiral welds on the pipe ground flush with the plate or sheet surface for a sufficient distance from the ends to allow proper installation of the flange.

4.13.8 *Manufacturing tolerances at ends.* Tolerances for pipe ends shall be in accordance with Sec. 4.13.8.1 and 4.13.8.2, as applicable. The length of pipe subject to the stated tolerance shall be that distance that comes in direct contact with the mating pipe or external appurtenances.

4.13.8.1 Out-of-roundness. The out-of-roundness of pipe ends shall be consistent with the diameter and wall thickness of the pipe supplied and the type of joint. Any out-of-roundness shall be limited to a smooth oval that may be jacked back to a circular shape.

4.13.8.2 Diameter. The diameter of the pipe ends shall be as determined by accurate circumferential measurement with a steel tape.

1. The circumference of the following types of pipe ends shall not vary by more than 0.196 in. (5.0 mm) under or 0.393 in. (10.0 mm) over the required outside circumference:

- a. Plain-end pipe.
- b. Beveled ends for field butt welding.
- c. Plain ends fitted with flanges.
- d. Ends fitted with butt straps for field welding.

NOTE: These circumferential tolerances are equivalent to $-1/16$ in. (-1.6 mm), $+1/8$ in. ($+3.2$ mm) on the resultant calculated diameter.

2. Ends for mechanical couplings shall have tolerances within the limits required by the manufacturer of the coupling to be used.

3. For lap-joint pipe prepared for field welding, the inside circumference of the bell end shall not exceed the outside circumference of the spigot end by more than 0.400 in. (10.2 mm).

4. For bell-and-spigot ends with rubber gaskets, the clearance between the bells and spigots shall be such that, when combined with the gasket groove configuration and the gasket itself, watertight joints shall be obtained under all operating conditions. The manufacturer shall submit details complete with significant dimensions and tolerances and shall also submit performance data indicating that the proposed joint has performed satisfactorily under similar conditions. In the absence of a history of field performance, the results of a test program shall be submitted.

4.13.9 *Squareness of ends for field-welded butt joints.* For pipe that is to be butt-welded in the field, the ends of pipe sections shall not vary by more than $\pm 1/8$ in. (± 3.2 mm) at any point from a true plane perpendicular to the axis of the pipe and passing through the center of the pipe at the end.

Sec. 4.14 Special Ends

By agreement between the manufacturer and the purchaser, the ends of the pipe may be supplied with joint configurations and tolerances other than those described within this standard. In such cases, pipe ends shall conform to the description of detail drawings provided by the purchaser.

Sec. 4.15 Specials and Fittings

Special sections shall be listed in the purchaser's order and shall be dimensioned in accordance with ANSI/AWWA C208 unless otherwise specified by the purchaser. The purchaser shall specify the maximum miter angle and centerline radius of elbows, special treatment of ends, orientation of laterals, and other design details not defined in ANSI/AWWA C208. Special sections not included in ANSI/AWWA C208 shall be fabricated in accordance with descriptions or drawings provided by the purchaser or in accordance with the manufacturer's drawings that have been approved by the purchaser.

Sec. 4.16 Fabrication of Specials

Special sections may be fabricated from pipe provided that the pipe meets the requirements of this standard. Special sections that are not fabricated from pipe may be made in accordance with Sec. 4.9, 4.10, 4.11, and 4.12 from any of the plate or sheet listed in Table 1.

SECTION 5: VERIFICATION

Sec. 5.1 Inspection

All work performed and material provided under the requirements of this standard may be inspected by the purchaser, but such inspection shall not relieve the manufacturer of responsibility to provide material and perform work in accordance with this standard. If the purchaser desires to inspect the pipe or witness the tests, reasonable notice shall be given by the manufacturer as to the time at which the inspection may be made.

5.1.1 *Quality assurance.* The manufacturer shall maintain a quality-assurance program to ensure that minimum standards are met. It shall include a certified welding inspector (AWS QC1) to verify that welders and welding procedures are qualified, procedures are being followed within the limitations of testing, and quality-assurance functions are being implemented.

5.1.2 *Access and facilities.* The purchaser shall have access at all reasonable times to those parts of the manufacturer's plant involved in the manufacture of the material ordered while work on the contract of the purchase is being performed. The manufacturer shall provide the purchaser with the facilities necessary to determine that the material is being provided in accordance with this standard. All tests and inspections shall be made at the place of manufacture prior to shipment.

5.1.3 *Rejection of pipe.* The purchaser may reject any pipe sections or special sections that do not conform to the prescribed test results and tolerances set forth in this standard and the purchaser's specifications.

5.1.4 *Rejection of material.* Material may be rejected and the manufacturer notified if the material contains unacceptable discontinuities when inspected at the mill or subsequent to acceptance at the manufacturer's plant, or if shown to be defective when properly installed and applied in service. In the event of such discontinuities or error in selection of materials or wall thicknesses, and if permitted

according to the purchaser's specifications, the manufacturer shall repair or replace such material.

5.1.5 *Finished pipe at delivery destination.* Shipments received at the delivery destination should be inspected by the purchaser for damage before and after unloading. Any pipe section or special section that shows dents or kinks on delivery may be rejected. A description of the damage and the reasons for rejection should be noted on the bill of lading and initialed by the carrier's representative. The manufacturer shall repair or replace the rejected sections subject to the purchaser's approval.

5.1.5.1 *Reconditioning.* Reconditioning of rejected sections shall be accomplished by rerolling or by pressure but not by hammering. Reconditioned sections shall be retested hydrostatically at the required pressure if deemed necessary by the purchaser.

Sec. 5.2 Test Procedures

5.2.1 *Hydrostatic testing of pipe.* Each length of pipe shall be tested by the manufacturer to a hydrostatic pressure not less than that determined by the following formula:

$$P = \frac{2St}{D} \quad (\text{Eq 5-1})$$

Where:

P = minimum hydrostatic test pressure (psi [kPa])

NOTE: By agreement between the purchaser and the manufacturer, other nondestructive test methods may be used in lieu of the hydrostatic test.

S = stress in pipe wall during hydrostatic test (psi [kPa]), which shall be 0.75 times the specified minimum yield point of the steel used, or as specified by the purchaser

t = wall thickness (in. [mm])

D = outside diameter (in. [mm])

5.2.1.1 *Other requirements.* The test pressure shall be held for sufficient time to observe the weld seams. There shall be no leaks. If joint rings are welded to the pipe after the hydrostatic test is performed, means must be provided to prove the soundness of the welds used for that attachment. Any leaks in the welded seams shall be repaired in accordance with Sec. 4.2.2, after which the pipe section shall be

retested hydrostatically. If on retest a section shows any leaks in the welded seams, it shall be repaired and retested.

5.2.2 *Testing of special sections.*

5.2.2.1 Nondestructive testing (NDT). Special sections shall be tested by nondestructive testing (NDT) methods, which may be visual inspection (VT), dye penetrant, magnetic particle (MT), ultrasonic (UT), or radiographic (RT), as specified by the purchaser. In the absence of such purchaser specifications, the NDT method shall be chosen by the manufacturer. Nondestructive testing methods are:

1. Visual inspection (VT) per ANSI/AWS D1.1, Table 6.1, Statically Loaded Nontubular Connections.

2. Magnetic Particle (MT) per ANSI/AWS D1.1, Section 6, Part D, 6.14.4, acceptance criteria per Part C, 6.10, and Table 6.1, Statically Loaded Nontubular Connection OR” per ASME Section V, Article 7, acceptance criteria per ASME Section VIII, Div. 1, Appendix 6.

3. Liquid Penetrant (PT) per ANSI/AWS D1.1, Section 6, Part D, 6.14.5, acceptance criteria per Part C, 6.10, and Table 6.1, Statically Loaded Nontubular Connections “OR” per ASME Section V, Article 6, acceptance criteria per ASME Section VIII, Div. 1, Appendix B.

4. Ultrasonic (UT) per ANSI/AWS D1.1, Section 6, Part F, acceptance criteria per Part C, 6.13.9, “OR” per ASME Section V, Article 4, acceptance criteria per ASME Section VIII, Div. 1, Appendix 12, “OR” API 5L, Sec. 9.7.4.

5. Radiographic (RT) per ANSI/AWS D1.1, Section 6, Part E, acceptance criteria per Part C, 5.12.1, “OR” per ASME Section V, Article 2, acceptance criteria per ASME Section VIII, Div. 1, Part UW, UW-51 or UW-52 as applicable, or API 5L, Sec. 9.7.3.

Special sections fabricated from previously hydrostatically tested straight pipe require 100 percent NDT of only those welded seams that were not previously tested in the straight pipe.

5.2.2.2 NDT qualification. Personnel performing NDT other than visual shall be NDT Level II or NDT Level I working under an NDT Level II qualified according to American Society for Nondestructive Testing, Recommended Practice No. SNT-TC-1A. Only NDT Level II or NDT Level III personnel shall interpret test results. The purchaser may specify alternate NDT qualifications to complete testing and interpretation of results.

5.2.2.3 Hydrostatic testing. When specified by the purchaser or when

required by service conditions, in lieu of NDT referred to in Sec. 5.2.2.1, special sections may be tested in a hydrostatic testing machine. Special sections that cannot be tested in a hydrostatic testing machine may be hydrostatically tested by welding on heads, or by use of blind flanges, or as specified by the purchaser. After testing, the ends shall be reconditioned when necessary. The required pressure shall be maintained long enough to permit visual inspection of all seams. Any section showing leaks shall be repaired in accordance with Sec. 4.2.3. Closing leaks by means of a caulking tool shall not be permitted. Repaired sections shall be retested.

5.2.2.4 Test certification. After testing, accepted sections may be stamped by the purchaser with some legible mark or identification. In place of a stamp of approval, the purchaser may request a certificate from the manufacturer concerning the tests.

Sec. 5.3 Calibration of Equipment

All instrument gauges and other testing and measuring equipment used in activities affecting quality shall be of the proper range, type, and accuracy to verify conformance with specified requirements. Procedures shall be in effect to ensure the equipment is calibrated and certified at no longer than annual intervals. Calibration shall be against measurement standards that have a known relationship to national standards, when such standards exist. Gauges must be calibrated and certified for the piece of equipment of which they are a part.

SECTION 6. DELIVERY

Sec. 6.1 Marking

A serial number or other identification mark shall be painted in a conspicuous location on each section of pipe and each special section. If the pipe is coated or lined, such marking shall be done at the shop and later transferred to the coating or lining. The constructor may be required to provide the purchaser with line diagrams, or laying schedules, showing where each numbered pipe or special section belongs in the pipeline. The numbers on such diagrams, or schedules, shall correspond with those painted on the pipes and special sections.

Sec. 6.2 Handling and Loading

The transportation and handling of coated or lined pipe shall be in accordance with the purchaser's specifications or, in the absence of such, in accordance with the pipe manufacturer's recommendation. Pipe shall be handled with proper equipment and in a manner to prevent distortion or damage. The use of hooks or clamps that could kink or bend the ends will not be permitted. Loading shall be done in such a manner as to prevent projections on any pipe length, such as ends with lap joints or ends with bells and spigots for rubber-gasketed joints, from rubbing against one another or against another pipe length.

6.2.1 *Out-of-roundness.* Pipe shall be loaded so as to ensure that out-of-roundness shall not exceed the limits specified by the purchaser.

Sec. 6.3 Affidavit of Compliance

The purchaser may require an affidavit from the manufacturer certifying that the pipe, specials, fittings, and other products or materials provided under the purchaser's order comply with all applicable provisions of this standard.

Kowsar San'at Espadana Co.

Kowsar San'at Espadana Co.

AWWA is the authoritative resource for knowledge, information, and advocacy to improve the quality and supply of water in North America and beyond. AWWA is the largest organization of water professionals in the world. AWWA advances public health, safety, and welfare by uniting the efforts of the full spectrum of the entire water community. Through our collective strength we become better stewards of water for the greatest good of the people and the environment.

1P-3.6M-43200-9/07-JP



Printed on recycled paper.